

HEXAGON TURNBUCKLE - CLOSED BODY

- THREADED LH / RH
- TO DIN 1479

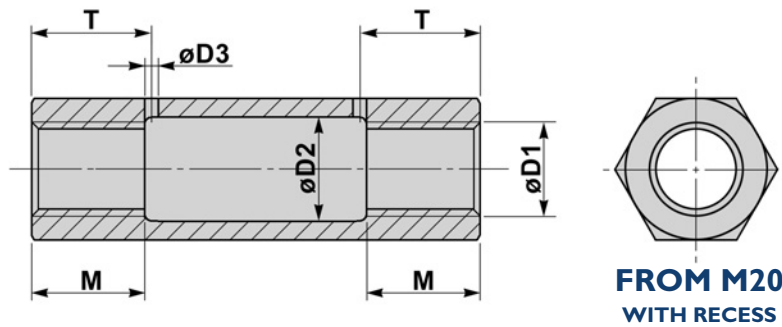
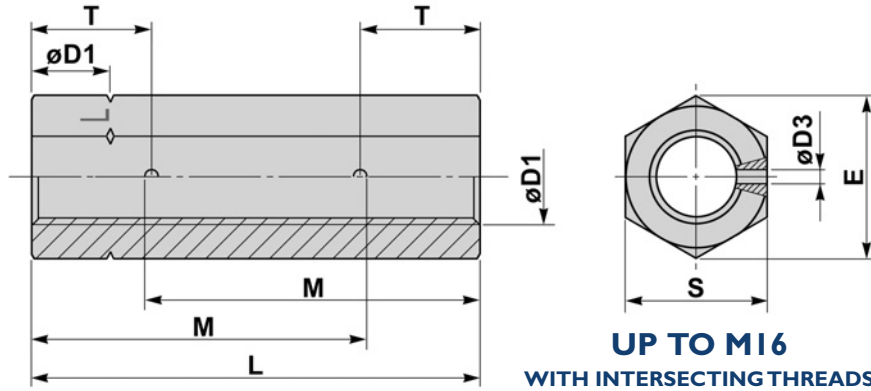

D1	D2	D3	L	M	S	E	T	ADJ
Thread	mm	mm	mm	mm	MAX mm	MAX mm	mm	mm
M6	---	4	30	22.5	10	11.05	9.5	15
M8	---	4	35	25	13	14.38	12	15
M10	---	4	45	33	16	17.77	14	21
M12	---	4	55	40	18	20.03	17	25
M16	---	4	75	55	24	26.75	22	35
M20	21	4	95	24	30	32.95	26	47
M24	26	4	115	29	36	39.55	31	57
M30	32	4	125	30	46	50.85	38	53

MATERIAL

CARBON STEELS
STAINLESS STEELS
ALLOY STEELS
B7, 4.6, 5.6, 8.8

FINISH

SELF COLOUR
GALVANISED
ELECTROPLATED
SHERARDISED
PTFE COATING

