

Adjustable Gate Eyebolts

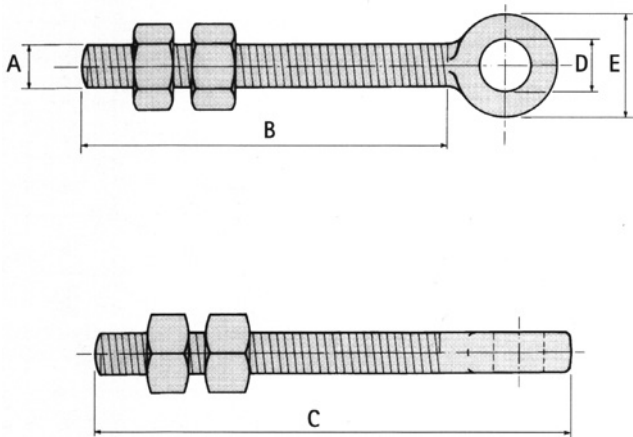

Code	To Suit Pin Dia mm	A metric Thread mm	B mm	C mm	D mm	E mm
35/1	12	M12	100	134	14	30
35/2	16	M16	100	140	18	38
35/3	16	M16	152	190	18	38
35/4	20	M20	115	159	21	45
35/5	22	M20	115	159	24	45
35/6	20	M20	152	197	21	45
35/7	22	M20	152	197	24	45
35/8	20	M20	204	248	24	45
35/9	20	M20	254	299	21	45
35/10	22	M20	254	299	24	45
35/11	25	M24	152	202	27	50
35/12	25	M24	204	254	27	50
35/13	25	M24	254	304	27	50
35/14	30	M30	152	212	33	60

Supplied with 2 nuts
Finish available: Self Colour, Spun Galvanised and Electro Plated

Heavy Duty Gate Eyebolts

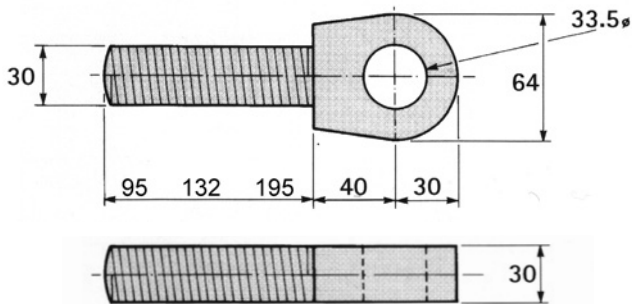

35/15

Longer Lengths Available
Finish Available: Self Colour and Galvanised

Pivot Block



35/18
Pivot block
50x50x50mm
31.5mm hole

Heavy Duty Hooks To Weld

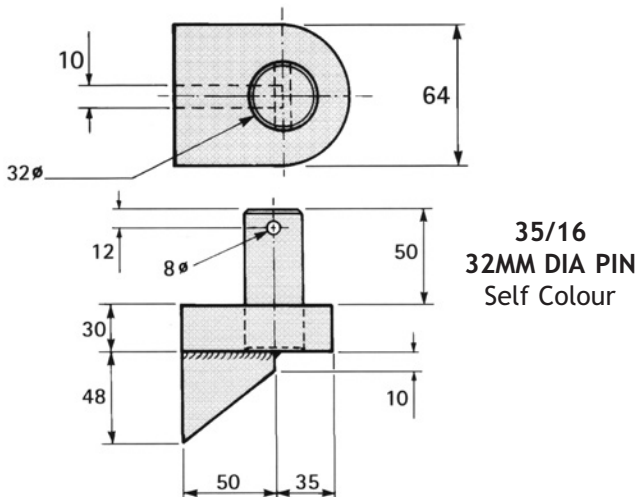

35/16
32MM DIA PIN
Self Colour

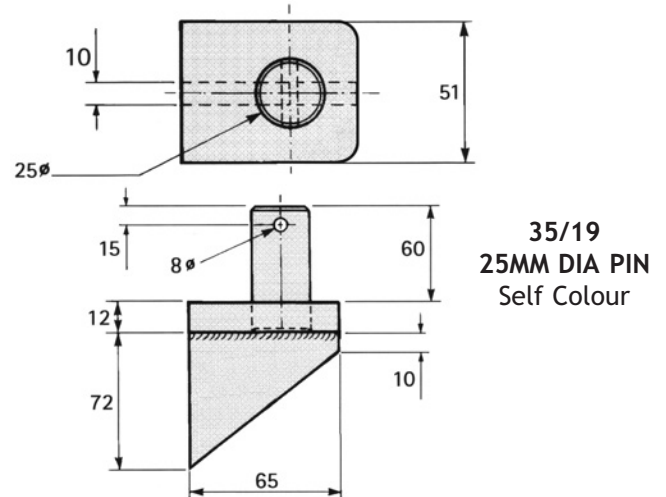

35/19
25MM DIA PIN
Self Colour