

DIN 444 - EYEBOLTS - TYPE A

BFE 13

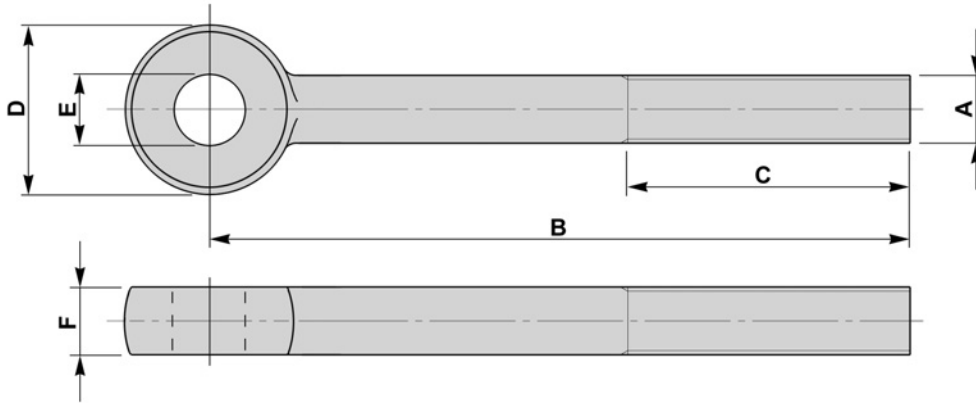

A	B		C	D		E	F	
	MIN mm	MAX mm		MIN mm	MAX mm		MIN mm	MAX mm
M6	35	90	18	12.9	14	6	8.52	9
M8	40	125	22	16.9	18	8	10.30	11
	126	140	28	16.9	18	8	10.30	11
M10	45	125	26	18.7	20	10	13.30	14
	126	150	32	18.7	20	10	13.30	14
M12	55	125	30	23.7	25	12	16.30	17
	126	200	36	23.7	25	12	16.30	17
	201	260	49	23.7	25	12	16.30	17
M16	70	125	38	30.4	32	16	18.16	19
	126	200	44	30.4	32	16	18.16	19
	201	260	57	30.4	32	16	18.16	19
M20	100	125	46	38.4	40	18	23.16	24
	126	200	52	38.4	40	18	23.16	24
	201	260	65	38.4	40	18	23.16	24
M24	100	125	54	43.4	45	22	27.16	28
	126	200	60	43.4	45	22	27.16	28
	201	260	73	43.4	45	22	27.16	28
M30	150	200	72	53.1	55	28	33.00	34
	201	300	85	53.1	55	28	33.00	34
M36	160	200	84	63.1	65	32	40.00	41
	201	300	97	63.1	65	32	40.00	41
M39	160	200	90	68.1	70	35	45.00	46
	201	300	103	68.1	70	35	45.00	46

MATERIAL

CARBON STEELS
STAINLESS STEELS
ALLOY STEELS
B7, 4.6, 5.6, 8.8

FINISH

SELF COLOUR
GALVANISED
ELECTROPLATED
SHERARDISED
PTFE COATING

NON STANDARDS
AVAILABLE TO SUIT
CUSTOMER REQUIREMENTS

DIN 444 - EYEBOLTS - TYPE B & C

BFE 14

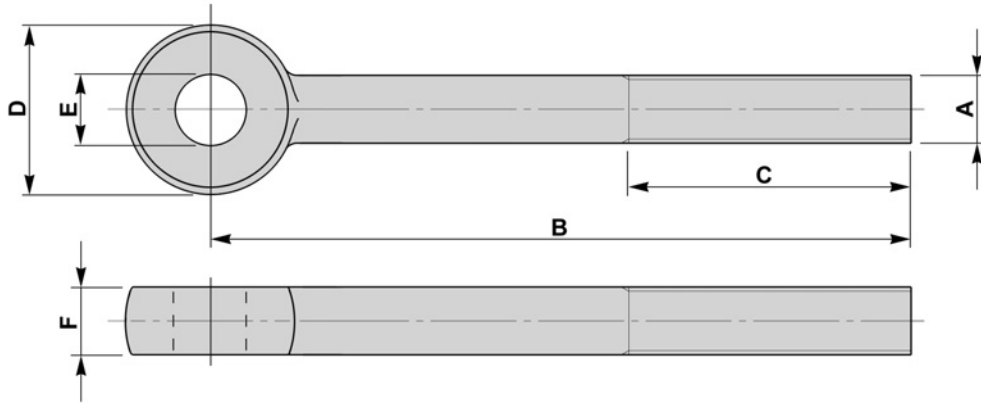

A	B		C	D		E	F	
	MIN mm	MAX mm		MIN mm	MAX mm		MIN mm	MAX mm
M6	35	90	18	13.57	14	6	6.85	7
M8	40	125	22	17.57	18	8	8.85	9
	126	140	28	17.57	18	8	8.85	9
M10	45	125	26	19.48	20	10	11.82	12
	126	150	32	19.48	20	10	11.82	12
M12	55	125	30	24.48	25	12	13.82	14
	126	200	36	24.48	25	12	13.82	14
	201	260	49	24.48	25	12	13.82	14
M16	70	125	38	31.38	32	16	16.82	17
	126	200	44	31.38	32	16	16.82	17
	201	260	57	31.38	32	16	16.82	17
M20	100	125	46	39.38	40	18	21.79	22
	126	200	52	39.38	40	18	21.79	22
	201	260	65	39.38	40	18	21.79	22
M24	100	125	54	44.38	45	22	24.79	25
	126	200	60	44.38	45	22	24.79	25
	201	260	73	44.38	45	22	24.79	25
M30	150	200	72	54.26	55	28	29.79	30
	201	300	85	54.26	55	28	29.79	30
M36	160	200	84	64.26	65	32	37.75	38
	201	300	97	64.26	65	32	37.75	38
M39	160	200	90	69.26	70	35	40.75	41
	201	300	103	69.26	70	35	40.75	41

MATERIAL

CARBON STEELS
STAINLESS STEELS
ALLOY STEELS
B7, 4.6, 5.6, 8.8

FINISH

SELF COLOUR
GALVANISED
ELECTROPLATED
SHERARDISED
PTFE COATING

NON STANDARDS
AVAILABLE TO SUIT
CUSTOMER REQUIREMENTS