

CHAIN ADJUSTERS

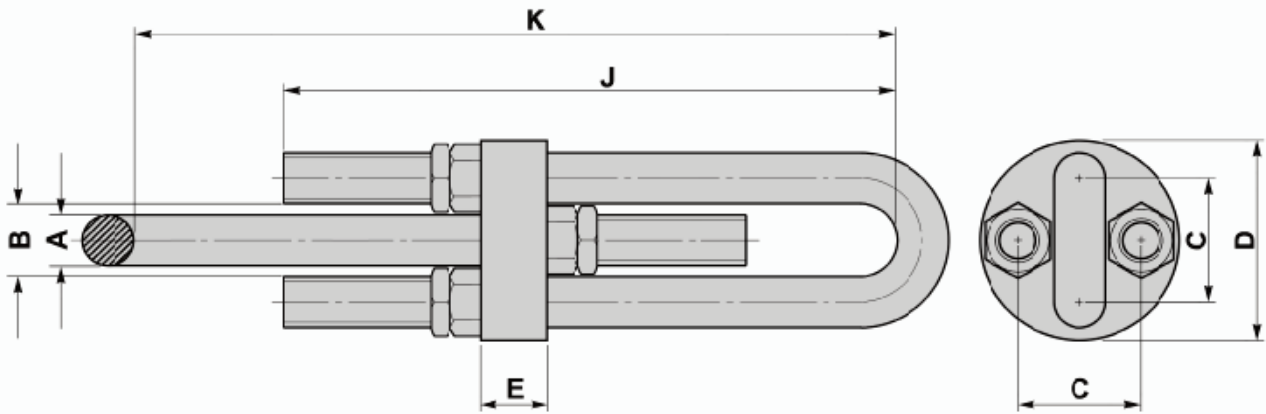

SWL	A	B	C	D	E	J	Weight	Thread Length	K Full Open	K Full Close
kN	mm	mm	mm	mm	mm	mm	kg	mm	mm	mm
80	24	38	62	120	25	220	11.7	150	450	300
130	30	48	78	150	30	330	25.8	185	615	430
180	35	60	95	180	40	445	32.0	200	775	575
250	42	70	112	200	40	500	46.0	230	865	637
320	45	80	125	220	40	540	56.0	240	920	680
410	52	83	135	275	50	630	85.0	270	1080	810
509	56	100	156	295	50	670	107.0	290	1145	855
726	68	112	180	320	80	880	190.0	370	1470	1100
1000	76	129	200	350	80	960	273.0	410	1595	1185

**NON STANDARDS MADE
TO SUIT CUSTOMER
REQUIREMENTS**

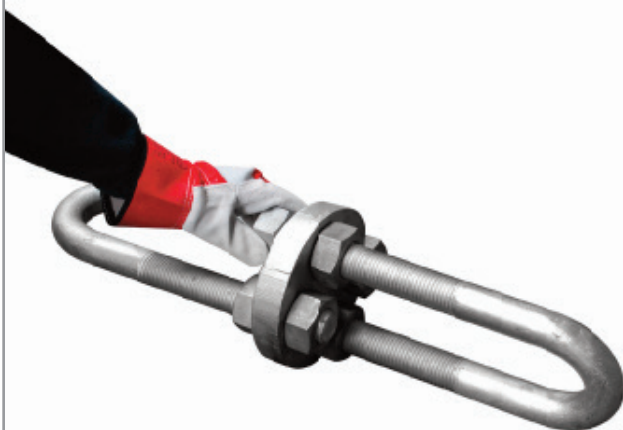

MATERIAL

CARBON STEELS
STAINLESS STEELS
ALLOY STEELS
B7, 4.6, 5.6, 8.8

FINISH

SELF COLOUR
GALVANISED
ELECTROPLATED
SHERARDISED
PTFE COATING

