

BS 529 - COLLARED EYEBOLTS - IMPERIAL

- TO BS 529 : 1944 PART I

BFE 18

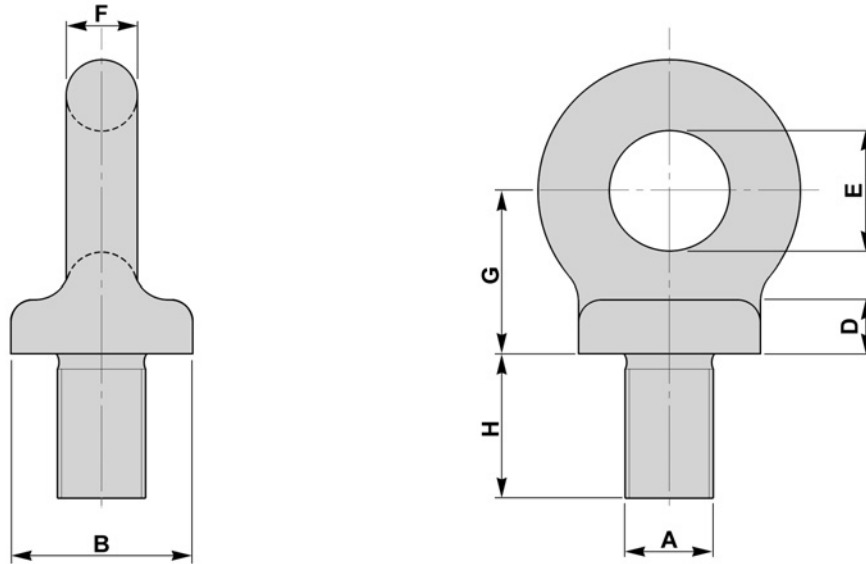

A	B	D	E	F	G	H	SWL		Weight Each
							TONNES	CWT	kgs
3/8	21	7	14	9	19	17	0	5	0.1
1/2	28	10	19	11	25	22	0	10	0.1
5/8	36	12	24	14	32	28	0	18	0.3
3/4	43	14	28	17	38	33	1	8	0.5
7/8	50	17	33	20	44	39	2	0	0.6
1	57	19	38	22	51	44	2	15	1.1
1. 1/8	64	21	42	25	57	50	3	10	1.6
1. 1/4	71	24	48	28	64	55	4	10	2.1
1. 3/8	85	28	57	33	76	67	5	10	3.6
1. 1/2	85	28	57	33	76	67	6	10	3.6
1. 3/4	101	33	67	39	89	77	9	0	5.6
2	115	38	76	44	102	89	12	0	9.1
2. 1/4	128	42	85	50	115	101	15	0	15.0
2. 1/2	143	48	95	55	127	111	20	0	17.7
3	172	57	115	67	152	133	30	0	30.4

MATERIAL
BS970 080A27 (EN5A)
STAINLESS STEELS
ALLOY STEELS
B7

FINISH
SELF COLOUR
GALVANISED
ELECTROPLATED
CHEMICAL BLACK
SHERARDISED

**SWL IS SHOWN FOR
VERTICAL LIFT**
**LONGER SHANK AVAILABLE
UPON REQUEST**