

BS 4278 - TABLE 3 & 6 - DYNAMO EYEBOLTS

BFE 21

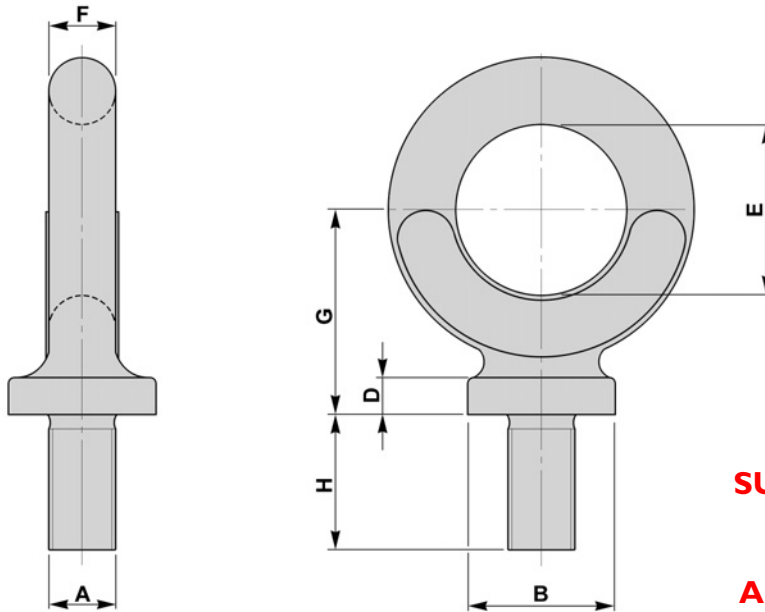

MATERIAL

BS970 080A27 (EN5A)

STAINLESS STEELS

ALLOY STEELS

B7

FINISH

SELF COLOUR

GALVANISED

ELECTROPLATED

SHERARDISED

PTFE COATING

**SUITABLE FOR VERTICAL
LIFTS ONLY**

**ANGLE LIFTS MUST USE
BS4278 TABLE 1**

BS 4278 - TABLE 3

A	B	D	E	F	G	H	SWL	Weight Each
mm	mm	mm	mm	mm	mm	mm	tonnes	kgs
M12	17	5	22	9	27	18	0.32	0.08
M16	23	6	29	11	34	23	0.63	0.14
M20	32	9	40	15	47	32	1.25	0.40
M24	40	12	51	19	60	40	2.00	0.78
M30	51	14	64	24	76	51	3.20	1.78
M36	63	18	79	30	95	63	5.00	2.44
M42	70	20	88	33	105	70	6.30	4.10
M48	79	22	99	37	118	79	8.00	7.70
M52	89	26	112	42	134	89	10.00	10.00

BS 4278 - TABLE 6

A	B	D	E	F	G	H	SWL	Weight Each
inches	mm	mm	mm	mm	mm	mm	tonnes	kgs
3/8	17	5	22	9	27	18	0.25	0.08
1/2	23	6	29	11	34	23	0.50	0.08
5/8	28	8	35	14	42	28	0.90	0.14
3/4	32	9	40	15	47	32	1.25	0.40
7/8	35	10	44	17	53	35	1.60	0.60
1.	40	12	51	19	60	40	2.00	0.78
1. 1/4	51	14	64	24	76	51	3.20	1.90
1. 1/2	63	18	79	30	95	63	5.00	2.44
1. 3/4	79	22	99	37	118	79	8.00	7.70
2	89	26	112	42	134	89	10.00	10.00