

BS 3032 - D SHACKLES - SMALL

- TO BS 3032 : 1958 TABLE I

BFL 10

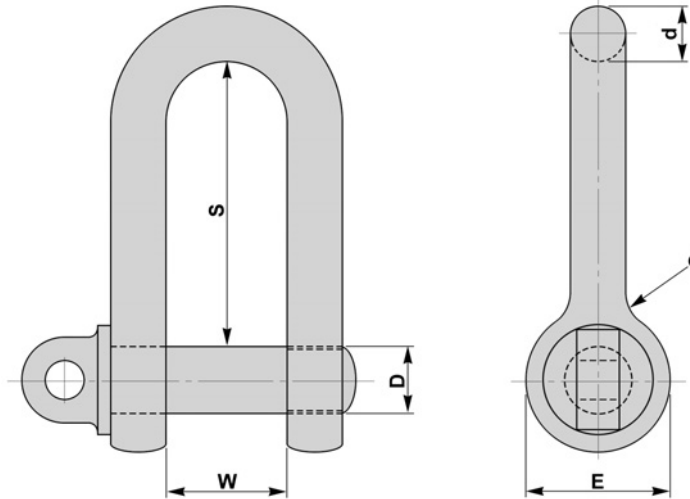

SWL		d	D	W	S	E	Weight Each
Tons	cwt	inches	inches	inches	inches	inches	kgs
---	6	1/4	3/8	3/8	7/8	3/4	0.1
---	12	3/8	1/2	5/8	1. 3/8	1	0.1
1	0	1/2	5/8	7/8	1. 7/8	1. 1/4	0.3
1	15	5/8	3/4	1	2. 1/4	1. 1/2	0.6
2	10	3/4	7/8	1. 1/4	2. 3/4	1. 3/4	1.0
3	10	7/8	1	1. 3/8	3. 1/4	2	1.5
4	10	1	1. 1/8	1. 1/2	3. 5/8	2. 1/4	2.3
5	10	1. 1/8	1. 1/4	1. 3/4	4. 1/8	2. 1/2	3.3
7	0	1. 1/4	1. 3/8	1. 7/8	4. 1/2	2. 3/4	4.5
8	0	1. 3/8	1. 1/2	2. 1/8	5	3	6.0
10	15	1. 1/2	1. 3/4	2. 3/8	5. 1/2	3. 1/2	8.6
13	0	1. 5/8	1. 7/8	2. 1/2	5. 7/8	3. 3/4	9.5
14	15	1. 3/4	2	2. 3/4	6. 3/8	4	12.5
16	15	1. 7/8	2. 1/8	2. 7/8	6. 3/4	4. 1/4	15.3
19	0	2	2. 1/4	3	7. 1/4	4. 1/2	18.4
20	0	2. 1/8	2. 3/8	3. 1/4	7. 3/4	4. 3/4	22.3
25	0	2. 3/8	2. 3/4	3. 5/8	8. 5/8	5. 1/2	30.9
30	0	2. 1/2	2. 7/8	3. 7/8	9	5. 3/4	35.9
35	0	2. 3/4	3. 1/8	4. 1/4	10	6. 1/4	48.1
40	0	2. 7/8	3. 1/4	4. 3/8	10. 3/8	6. 1/2	54.9
50	0	3. 1/4	3. 3/4	5	10. 3/4	7. 1/2	79.0
65	0	3. 5/8	4. 1/4	5. 1/2	13. 1/8	8. 1/2	109.9
80	0	4	4. 5/8	6. 1/8	14. 1/2	9. 1/4	147.6

MATERIAL

BS 970 150M19 (EN14A)

STAINLESS STEELS

B7

FINISH

SELF COLOUR

GALVANISED

ELECTROPLATED

SHERARDISED

CHEMICAL BLACK

**NON STANDARDS
AVAILABLE TO SUIT
CUSTOMER REQUIREMENTS**